

Are you thinking about getting a scale for a small tank or a large silo or perhaps something in between? Or are you interested in measuring forces?

Read parts of this information and you save yourself time in the end!

This is a small publication that you can use to get ideas on how to build a scale using components (load cells, mechanics, electronics, software, etc.)

There are a number of complete scales such as floor, pallet and beam scales which can be chosen if they are suitable. If they aren't, you usually have to choose separate load cells and electronics. The same results are achieved as with a complete scale; however it will be more appropriate to the application it will be used for.

Table of Contents:		Page		
General		1	Power measurement	10
Choosing electronics and a load cell	2-4		Choosing suitable electronics	11
Silo scales	6-7		General advice for load cell assembly	12-13
Tank scales and pallet/beam scales	8		If a scale is behaving "oddly"	14
Suspended loads or forces	9		Documentation	15



A few examples of complete scales which may be suitable; there are many complete scales available at www.vetek.se



110AH 5 - 120 tons
High accuracy



VZ101BH 0.05 - 20 tons



OCS-A 2 - 20 tons



OCS-G 1 - 15 tons
With heat shield



ERT 2 - 200 tons
Radio controlled



KF 30 kg/10 g



Stud bolt 535TS
For axles of up to
100 tons

A few examples of load cells and complete scales appropriate for suspended loads; there are many complete scales available at www.vetek.se

To build your own scales, one or more load cells will definitely be needed to pull or to press on. A few examples:



VZ266AH/AS



PA6181



VZ563YH/YS



VZ247
Mini load cell



Model 108



202WA Low profile
max 200 kg



Canister for max 500 tons

Load cells can have many different appearances and can weigh from a few grams up to many hundred thousands of kilos.



563YHM4



563YHM5



AMF



Spacer



Assembly unit for C2S

There are many different accessories to facilitate the assembly of load cells. Here are a few examples:

The Electronics

The basic principle is always the same. One or more load cells must be mounted into a mechanical construction and some form of electronics is required, with or without a display, which often communicates with a computer, PLC, etc.

There are many types to choose from, everything from simple transmitters which emit an analogue or digital signal, to a remote computer or similar. Remember that a display close to the silo/tank will often be appreciated by the floor personnel.

The output signal can be e.g. analogue 4-20 mA, digital RS232/485, Profibus, radio transferred, an alarm or a contact/transistor.

One good compromise is a wall-mounted transmitter which also has a Display and tare option, e.g. the LCD-A type. There are now wholly-sealed indicators, IP69K, which even withstand knocks. If you want one that is extremely durable, choose X320.



A few examples of different types of electronics you can use.



A few examples of what you can put together to design your own special application.

The Load Cells

There are usually 3 or more load cells placed in each corner of the tank, silo, feeder or whatever kind of "silo/tank" you weigh in. Remember:









1. A tank with 3 load cells often has a mechanically stable position, but can sometimes be somewhat unstable. A tank with 4 load cells can often stand steadier but can "rock" somewhat. You can compare this with a three or four-legged stool.
2. Most load cells are intended for tank/silo weighing, pallet scales and many other applications have "standardised" outgoing signals, i.e. they signal just as much for a given load (e.g. 1 ton). This means that many load cells of the same type can be coupled in parallel. The scale will show the same, regardless of uneven loading.
3. For many weight platforms, only one type of load cell is used - a single point type. They often give different signals for a given load and cannot be coupled in parallel. The reinforcement is adjusted in

- the indicator so that the scale will weigh correctly. The scale platform still shows the same weight, regardless of where the load is placed on the platform.
4. The load cells are mounted so that all of the load being weighed will weigh down the load cells and nothing else will weigh down or carry the load. In and out feeding is insulated so that it will not affect the silo/tank. Naturally, a tank/silo being weighed must be mechanically insulated from nearby tanks/silos which are also going to be weighed.
 5. Remember that the silo/tank must remain on the load cells and not glide sideways or be lifted upwards during e.g. a storm. It is important that there is not too much friction in the construction between the part that weighs and its surroundings.
 6. If there are strong vibrations it is always possible to use rubber dampeners on the load cells.
 7. Temperature tensions can occur in a load cell construction if the distance between the load cells and silo/tank is exposed to temperature variations. There are simple solutions which will reduce these side effects. You can e.g. allow the tank legs to glide sideways somewhat on bearings/rolls/glide rails or use rubber dampeners.
 8. When deciding between nickel-plated or stainless steel load cells, the environment will affect the decision. If it is only occasionally wet, the nickel-plated steel will work well, however if the environment is aggressive and/or very damp then choose stainless steel. Some stainless steel load cells are classed to withstand being drenched during a period of time.
 9. If the load cells are being installed in an old silo/tank, the silo/tank must be lifted to assemble the load cell and any accessories. Be careful not to overload the load cells when setting a tank down. You can make blocks to use instead of load cells. Do not weld onto the silo/tank when the load cells are installed. Assemble a ground braid past the load cells so that they will be protected from ground currents should there be any errors when welding.
 10. The factory-new silos/tanks can be prepared for load cell assembly with accessories; however most often the accessories cannot be assembled in the workshop.
 11. For applications where you can expect static electricity (e.g. silos filled with plastic granulate), you must try to reduce the effects as much as possible. For example, by grounding the refilling hoses and the silos and by carefully separating the scale through galvanisation during remote transfer of measurement data.
 12. Nearly all load cells today, can be coupled in parallel in a junction box. Remember that a good connection is important and that cables must be installed so that no water can enter the box. It is preferable to use couplings which face downwards.

Choosing a load cell.

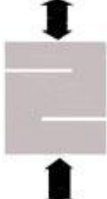
It is important to choose correctly from the beginning. The choice will often affect the mechanical parameters of the tank and load constructions in the long run

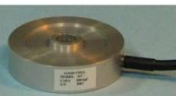
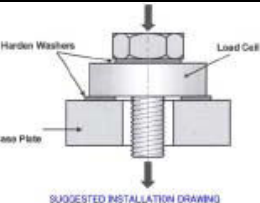
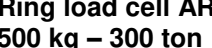
Nearly all load cells are built on the same principle. Nearly all are equipped with a wire expansion sensor; it is mostly the mechanical design that differs. Below, are a selection of price worthy load cells with different functions, materials and IP Codes.

<p>Load cell TS 0.05 - 7.5 tons</p> 	<p>Stainless steel IP68. OIML C2 or C3.</p> 
<p>Load cell VZ101BH/BS 0.50 - 20 tons</p> 	<p>Nickel-plated steel. IP67. OIML C3.</p> 
<p>Load cell TCA 1-50 kg</p> 	<p>Aluminium. IP20.</p> 
<p>Load cell 110AH 5-120 tons</p> 	<p>Nickel-plated steel. IP67. (special for overhead cranes)</p> 
<p>Washer load cell 247W 30-500 kg</p> 	<p>Nickel-plated steel. Thin load cell.</p> 
<p>Ring load cell AR 500 kg - 300 ton</p> 	<p>Nickel-plated steel. IP65.</p> 

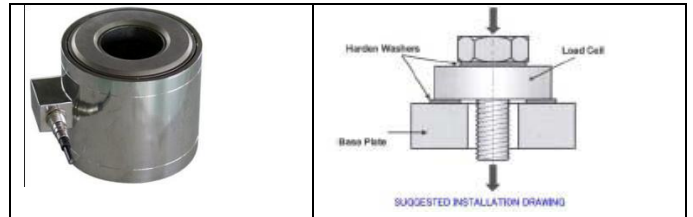

Load cell ARL 0.5 - 300 tons
Nickel-plated steel. IP67. (Also available in stainless steel)

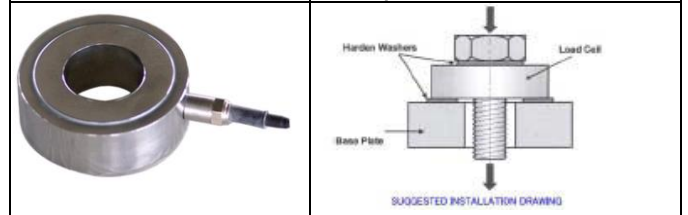

Load cell PA6181 0.25 kg - 50 tons
Nickel-plated steel. IP67.

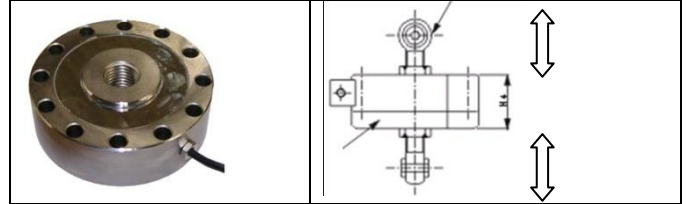

Load cell VZ563YH 0.1-20 tons
Nickel-plated steel. IP67. OIML (also available in stainless steel)

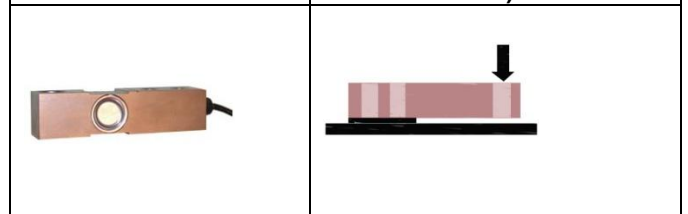



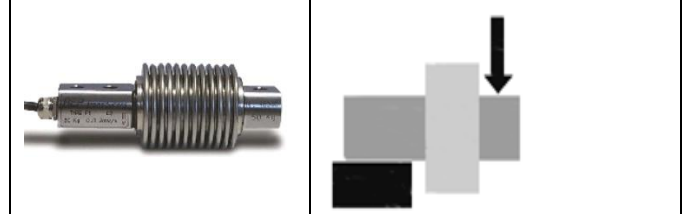

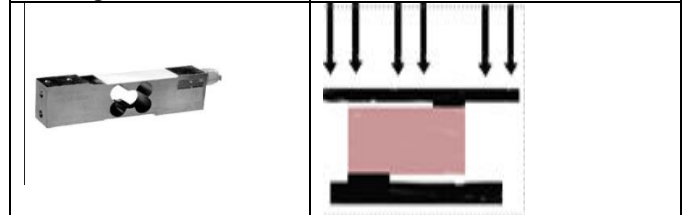

Load cell FXC 10-200 kg
Stainless steel IP68. OIML C2 or C3.

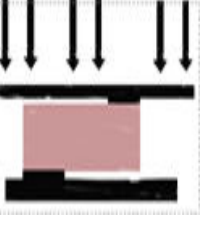

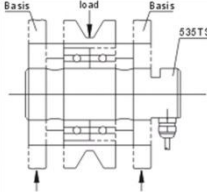
Load cell 108TS 10-150 kg
Stainless steel IP67. OIML C2.

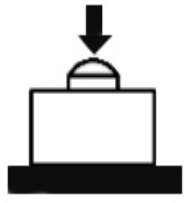

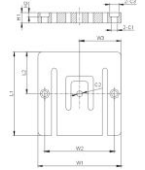
Load cell 108LA 60-300 kg	Aluminum. IP66 OIML C3 (Also available in stainless steel)
	
Pin load cell 535TS 2 – 100 tons	Stainless steel IP67.
	
Canister load cell 106BH 100 - 500 tons	Load cells for the very heavy weights
	
Low profile Load cell 202WA 15 – 200 kg	Load cells from 15 up to 200 kg for low profile scales
	

High temperature?

Most load cells withstand approx. -25 to approx. +70 °C as standard. Accuracy is then somewhat reduced outside the area approx. -10 to approx. +40 °C.

There are special load cells which withstand much higher temperatures.

Application in water?

There are different types of stainless steel load cells which are classed as IP68 and withstand a 1 m column of water for 100 hours.

Silo scales

It is common to choose compression load cells of nickel-plated steel or stainless steel of a "button type" e.g. VZ266AH or VZ266AS or C2S. There are very price worthy nickel-plated or stainless steel load cells of class IP67/ IP68 which are available in capacities of up to 100 tons.



VZ266AH for loads from 0.25 up to 30 tons. There are models for up to 500 tons.



This type of load cell can be assembled under most types of silos. One load cell per leg or one load cell on e.g. a three-legged silo, unless the demands for accuracy are very high, e.g. when weighing CO₂.

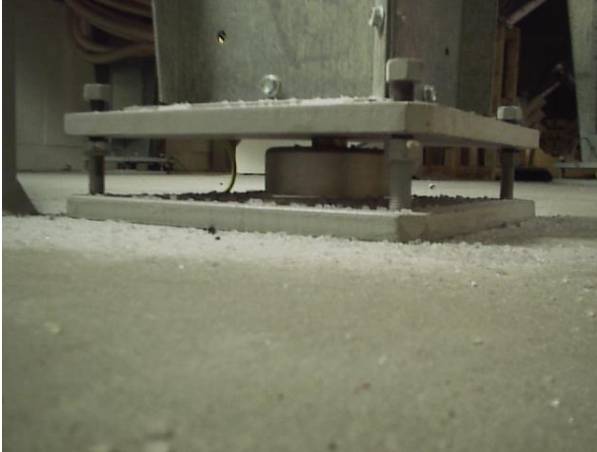

For the simplest forms you just lift the foot of the silo up and install the load cell. The nuts must be loose to prevent any upward and lateral forces. The accuracy will often be excellent.



A more advanced form is a completely assembled unit which prevents lateral and lifting movements and allows for easy service. Remember to always protect the load cells when welding.

NOTE: This is not a universal solution which can be factory-assembled.



Perhaps not for silo scales but for 2-ton loads. The size of a Swedish 5-krona.



In vibrating environments, the load cells can be equipped with special dampeners.

Mounting example on an already installed silo.

For a silo with difficulties to mount load cell and lift it several cm, this is a good example of modifying the inside construction. It's only necessary to lift it 6-7mm, which is a great benefit if the construction is already made with feeder screw etc.



Tank scales and pallet/beam scales

In smaller tank scales of up to 5-10 tons and in different types of pallet and beam scales, it is common to choose a shear power cell of nickel-plated steel, e.g. VZ563YH, or stainless steel IP68 e.g. VZ563AS.

However, that type of "button" load cell described above can also be used.



Standard pallet and beam scales



VZ563YH for loads from 0.1 up to 20 tons.



Perfect for special beam scales, low profile floor and pallet scales.

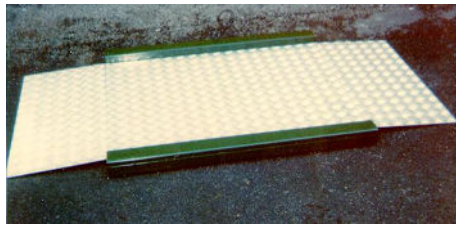

Normally assembled with machine feet.



..or tank installationsfixed.....and mobile.....

For easy applications up to about half a ton and where the demands for accuracy are high, a bending beam load cell with a bellow is recommended.



Weighing suspended loads or forces

A so-called S-Load cell is usually used. You normally attach a link head or similar. There are also models with holes for a shackle.



TCA, TS or VZ for loads from 1 kg up to 20 tons



With link heads



T20 and D100 for loads from 5 up to 100 tons. Hole for shackle.



Tensile testing

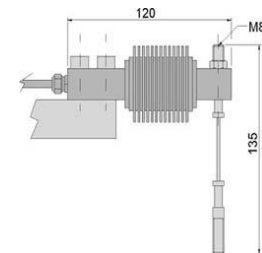
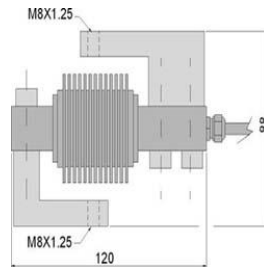

When very high accuracy is required in difficult environments, the above assembly variations of a bending beam sensor are good alternatives.



110AH for loads from 5 up to 120 tons. Hole for shackle.
Extra high accuracy, especially in overhead crane scales

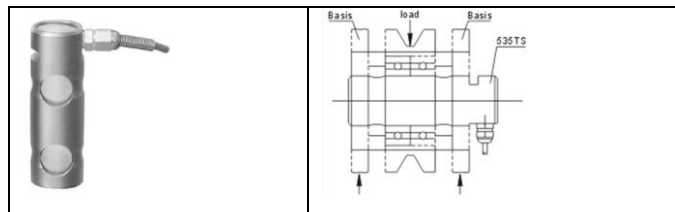

A load mounting pin with a wire play can be a convenient way to solve a force-measurement problem.



A Ring load cell can be a good construction for measuring forces in nuts and wires.

Measuring force

Most often, you know how much force you want to measure. However, you may not know that load cells have many mechanical divergences. Choosing the correct load cells can save many hours work in modifying the mechanics so that everything will fit together.

Here are a few tips to remember:

For pure compression forces where the force is centered.



An "ordinary" load cell with a knob, e.g. VZ266 or C2S, is often simple and the best. Available from a few kilos up to 100 tons. Can be turned upside down or used in any direction of choice.



A load cell with thread, e.g. PA6181 is a good alternative if you want to e.g.

- make an adaptor to e.g. press gas springs.
- make an adaptor for a ball

Tensile forces



An "ordinary" S-Load cell threaded top and bottom, e.g. VZ101BH or TCA/TS are often simple and the best. Available from 1 kg to 20 tons. Adapted for link heads.



S-Load cells T20 and D100 for loads from 5 up to 100 tons. Hole for shackle.



"Overhead crane" load cells. 110AH for loads from 5 up to 120 tons. Hole for shackle. Extra high accuracy.

2 types of indicators with peak/hold-function



S-Load cells. N320 for loads from 5 up to 120 tons. Hole for shackle.



Peak/hold is used to hold the top value of a force until it is equalized by pressing a button.



TI-500 P/H can be mounted on a wall or placed on a table. MP1 is for panel mounting.

Checking pressure processes



Digiforce 9310 is a meter for checking that the manufacturing times during different pressure processes are within the given limits.

Complete force meter



VB2-10K is a complete 10-ton meter with Display.
Can be equipped with an adaptor for individual adaptation.

Choosing suitable electronics for weighing and force measurement

Note: The models below are examples; there are many more similar models with similar properties.

The simplest form is a scale transmitter connected to a PLC/PC



AWT20L. The outgoing signal is analogue 4-20 mA proportional to the measuring area of the scale. Feed: 12-24 VDC

Scale indicator with tare



TI-1200-S is a model for wall/table mounting. The Display shows the weight. It can be tared (zeroed with load) and show the net / gross values. It has a RS232 outlet. Feed: 9-12 VDC



DGQ is a model for panel mounting. The Display shows the weight. It can be tared (zeroed with load) and show the net / gross values. It has a 2 off alarm and a RS232 outlet. It can be used for simple dosing. Feed: 12-24 VDC Option: 4-20 mA.



N320-K302 is an extremely light model for mounting on panels or walls. The Display shows the weight. It can be tared (zeroed with load) and show the net / gross values. Feed: 12 VDC or chargeable batteries.



LCA-D is a model for wall mounting. The Display shows the weight. It can be tared (zeroed with load) and show the net / gross values. It has a 2 off alarm and a RS232/485 and 4-20 mA outlet. Feed: 12-24 VDC



The DFW-series' indicators are a whole series of different models for different applications. With functions containing nearly everything a scale technician can be interested in.

Software

There is a number of different software. Most manufacturers of indicators can offer everything from simple software for logging measurement values into Excel to more complex ones for the system surveillance of tanks.

However, the most common for customers to use the standard data inputs (e.g. RS232, RS485, etc.) and enter them into their own PLC or PC.

GENERAL MOUNTING ADVICE FOR LOAD CELLS

Load cells can be roughly divided into 5 main groups:

1. Load cells of the type "Button load cells" "compact pressure or tensile load cell", Canisters or other cylindrically formed load cells, e.g., where the load is placed directly on the load cell, e.g. the types below, see figure below.
2. Load cells of the bend beam/shear force type. They often have one assembly hole at one end and two at the other end. They are often square or round in form. These are most often mounted horizontally.
3. S-formed load cells for suspension (or compression loads). These often have one threaded hole at the top and one at the bottom.
4. "Single point" or so-called "off-centre" load cells. These often have 2 or 4 mounting holes at each end. They are normally made of aluminium. They are normally mounted horizontally with an upper wall plate and a lower plate of aluminium or stainless steel.
5. Other load cells.

Mounting load cells of the bending beam/shear force type

The assembly is similar for all types; the difference is the attachment of the load cell and the design of lateral movement and lifting protection. It is often not necessary to screw the load cells onto the foundation.

Assembly proposal

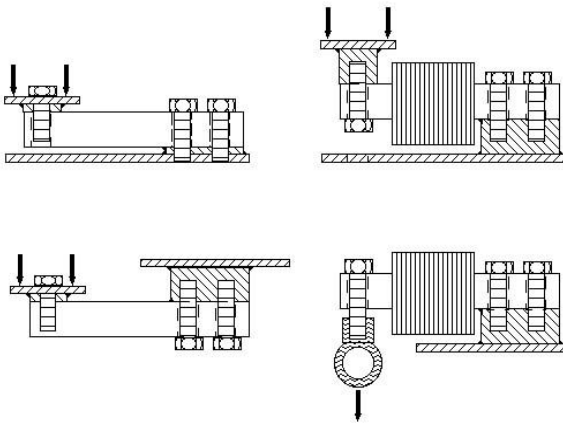

Mounting load cells of the bending beam/shear force type

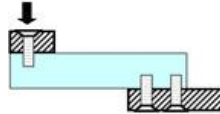

The assembly is similar for all the types; the difference is in the attachment of the load cells and the design of protection against lateral and lifting movements. The load cell is usually assembled horizontally with one end having two holes facing towards the foundation and the other end with one hole facing towards the object.

It is important that the load cell is assembled against a spacer (e.g. a washer) out from the foundation and that the load is brought as close to the attachment hole as possible (see sketches).

Assembly of "Button load cells" and "canister" types

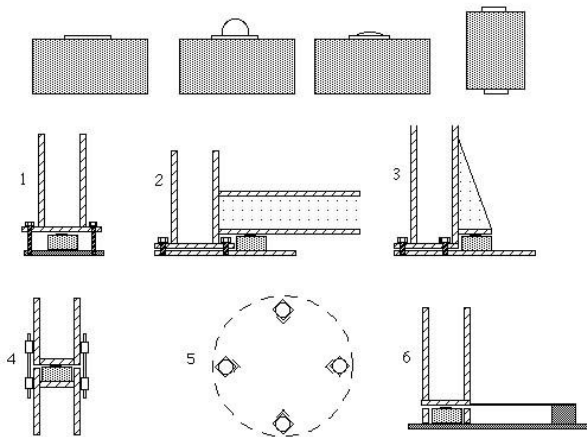

Assembly proposal according to picture 1

Is based on the bolts which normally hold the silo legs in place being uncovered and that the load is taken by the load cell. The bolts then actually serve as a safety precaution against the leg moving sideways and as lift protection.

Assembly proposal, picture 4

The task of the guides is to function as side and lifting protection.

Assembly proposal, picture 6

The leg can be fixed with lateral protection of this type. Thin iron or a pole which do not take any loads can be used as protection against lateral movement.

Assembly of "Single point" or so-called "off-centre" load cells

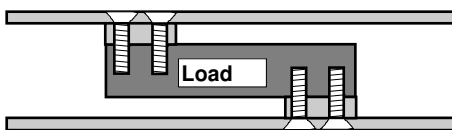

"Single point" or so-called "off-centre" load cells are mounted between an upper and lower plate. Their stability is decided by the mechanical design of the plates and washers.

The load cell gives the same signal regardless of where the load is applied to the upper plate.



General Advice:

1. The basic principal for assembling load cells is that the silo/tank (empty) should be able to be pressed upwards with a jack or similar so that the load cell can easily be exposed for control and calibration.
2. The silo/tank must be mechanically locked so that it cannot move laterally or upwards (the movement of the load cell is less than one half mm at nominal strength/power)
3. If load cells are mounted under 1 of 3 or 2 of 4 legs, it is usually sufficient to have a simple side/lift protector on the legs with the load cells.
4. When assembling the silo/tank, dummies can be used instead of load cells to avoid chocks. The silo can even be placed on jacks. It doesn't matter how you arrange it, as long as the load cells are not overloaded during assembly.
5. When the silo/tank is placed back in position on top of the load cell, it must be done with great care to avoid large dynamic forces.
6. If load cells of the bending beam/shear force type are used, check to make sure the force is directed in the direction of the arrow. If you should happen to turn the load cells the wrong way, you just have to shift the signal wires to get the same result as with turning the load cells.
7. Check that all force from the silo/tank affects the load cells and especially that the force affects the load cell at the right place; there should not be any point of friction taking on load.
8. If the wires don't reach the indicator, couple them together in a junction box beside the silo/tank. Solder the wires together with the same colour (parallel coupling) and attach them in the box.
9. As an alternative, there are complete junction boxes with a terminal for each load cell for this purpose. The point of a junction box is that it is easier to couple many load cells together. Also, it is possible to corner-adjust them individually, however this is not necessary for standard tank and silo scales.
10. To avoid electric shocks from e.g. lightning, when assembling outdoors, make a ground braid between the leg and foundation plate, as close to the load cell as possible.

Important to all types of load cells

- When welding in the silo/tank, measures must be taken so that no ground current can pass through the load cells. It is best to disassemble them during this work.
- The load cells must be protected from overloading. Most load cells can be continuously overloaded 50 % above their capacity.
- All connections to the scale (filling, emptying pipes, cables, etc) must be flexible so that they do not take on any load.
- Always place the load cell cable so that NO water can run alongside it and into the load cell.

The most common causes for load cells breaking

- Overload when something has been "dropped" onto the scale platform, the tank or directly onto the load cell. A weight far below the capacity of the load cell can cause too high dynamic force on the load cell during shock loading.
- It is a good idea to protect the scales from being driven over by trucks.

Other causes for errors

- The cable can be mounted in such a way that it is exposed to pulls and is simply pulled off of the load cell.
- Construction welding above the load cell.

Fast check of load cells

- Uncouple the signal wires of the load cells and have only the power feed coupled.
- The load cell has a standard sensitivity which is expressed in V/V. Assume 2.0 mV/V
- The load cell has a standard maximum load of e.g. 1000 kg.
- The scale indicator has a feed voltage to the load cell which can vary somewhat between different scale indicators. Assume 10.05 V.
- The load cell is balanced to nearly zero, but can diverge by < 1% (in this case approx. 0.2 mV) from zero. Divergences are small and are of no real importance, so we disregard them.
- The outgoing uncharged signal of the unloaded load cell will then be $0 / 1000 \times 10.05 \times 2 = 0 \text{ mV}$
- The outgoing signal of the load cell at maximum capacity e.g. at 1000 kg will be $1000 / 1000 \times 10.05 \times 2 = 20.1 \text{ mV}$
- The outgoing signal of the load cell should lie between 0 and 20.1 mV in proportion to the load (0 - 1000 kg).

Colour codes of a few standard load cells

In general	Load cell types: SBS, PA, LCD, SB2, SC, SQB, CR, LPX, PST, ST, PT	All types beginning with VZ	C2S, TS, TCA AKA	Load cell DT-101	355	AG	1042
Load cell feed Excitation E+	Red	Red	Red	Red	Blue	Brown	Green
Signal load cell S+	Green	Green	White	Green	White	Yellow	Red
Signal load cell S-	White	Blue	Yellow	Yellow	Red	White	White
Load cell feed Excitation E-	Black	White	Black	Blue	Black	Green	Black

A few load cells have 6-core connections

The extra two wires are included because some indicators have inputs for compensating the different lengths of cables. These wires are normally called SENSE+ and SENSE-. These wires are either coupled from the indicator (if it has a 6-core connection) between the indicators and box or are coupled to a jumper between Exc+ and SENSE+ as well as Exc- and SENSE- on the indicator terminal.

Note: If S-load cells are being used and the force is pulling, then the coupling ingoing load cell + and ingoing load cell -, must be switched.

If a scale is behaving "oddly"

Most types of scale electronics have many possible settings. Here are a few of the most important terms you need to understand as a user:

Scale capacity

The maximum load the scale can show on its display.

Zeroing (often performed with the button marked ZERO)

An area which (in Europe) is often approx. 2 % of the capacity. This should only be used when the scale is overloaded and does not show zero.

Taring (often performed with the button marked TARE)

The scale is "zeroed" when it is loaded. Used to "tare" off e.g. packages, pallets, etc.

Auto-power off

If the scale remains in the same position, unloaded or loaded, it will shut off when this function is activated. The time for this can often be changed and there is often an off-mode for disconnecting this function.

The divisions of the Scale often called scale divisions

That is, how many parts the scale's total measurement area is divided into. Example: A 15 kg scale which has 15,000 scale divisions is shown with a 1 g resolution. When verifying and for validation, the scale is usually verified with 2000 or 3000 scale divisions.

Gravitation

The Earth's gravitational pull affects all scales; however this small error can often be calibrated off locally. When verifying, the scale is calibrated for gravitation for that place it will be used. For example, a scale for 100 kg which will be delivered to Holland is calibrated with 99.940 kg at Vaddö. Some table scales have automatic internal calibration. It doesn't matter where they are used.

Zero sequence areas

Most indicators have an area around the zero point where the scale will try to zero itself and in this way remove the effects of long-time use, e.g. effects from changes in temperature. There may be e.g. 5 scale divisions.

Possible problem: If you want to weigh a very small amount on an unloaded scale, it is possible that the scale may zero itself automatically. One way to avoid this is to place a smaller weight on the scale and tare it. The scale will then show increased, or decreased weight when it is loaded. Another possibility is removing the function.

Movement area

The area indicating movement between current values compared with the previous value. If the value is stable for a certain period of time within the area, the value is considered OK and the desired command can be performed.

A symbol is usually seen on the display which shows stability.

Possible problem: If it is often difficult to give the scale a command, e.g. pressing the tare button, then one of the scale's parameters may require changing.

Digital filter

Average value building for higher accuracy. The higher the filter value, the higher the accuracy and slower the reply time.

Possible problem: If the scale is too "slow" and takes a long time to show the correct value, then filter value should be reduced.

Documentation

Most scales are available with different types of documentation. This can include:

- Instructions and manuals. An instructions manual is normally included with the goods on delivery. For environmental reasons, the complete documentation is available for downloading on our homepage.
- Calibration certification is performed by Vetek. This is not standard, but can at a lesser cost be performed at a later date. This will otherwise be included when ordered together with the goods.
- The calibration certification with a declaration of manufacture is performed by Vetek. This is not standard but can at a lesser cost be performed at a later date. This will otherwise be included when ordered together with the goods.
- Calibration certificate-Verification/Validation is performed by SP Technical Research Institute of Sweden (Statens Provningsanstalt).
Languages: Swedish or English. All originals are sent to the customer. This will be listed as a separate item on the invoice.

Regarding series numbers on load cells

"When load cells have double series numbers, the Swedish number always applies before that from the supplier. We have not stored the series number of the supplier in a cross registry. It is also doubtful information, since it never contains information about the manufacturer.

The Swedish series number label contains clear information about the origin of the load cell (Vetek), not where it was manufactured. Legally, this means that Vetek stands as the importer and is responsible for the delivered good fulfilling those specifications stated in the information sheet compiled by Vetek.

If calibration or verification has been performed, there will be a certificate of calibration (or a verification certificate) with a series number on the load cell(s) and scale instrument".